**IMPORTANT
READ CAREFULLY BEFORE USE
KEEP SAFE FOR LATER REFERENCE**



BMW Motorrad

**TRANSLATION OF THE ORIGINAL
OPERATING INSTRUCTIONS**

EN

E-Scooter

X2City

KW074-DAMS99, KW074-DBMS99, KW074-DCMS99, KW074-DDMS99

Copyright

© KETTLER Alu-Rad GmbH

Distribution or reproduction of these operating instructions and utilisation or communication of their content is prohibited unless expressly approved. Any infringement will render the offender liable for compensation. All rights reserved in the event that a patent, utility model or industrial design is registered.

1	About these instructions	5
1.1	Manufacturer	5
1.2	Laws, standards and directives	6
1.3	Other valid documents	6
1.4	Subject to change	7
1.5	Language	7
1.6	Identifying	8
1.6.1	Operating instructions	8
1.6.2	E-Scooter	8
1.7	For your safety	9
1.7.1	Instruction, training and customer service	9
1.7.2	Basic safety notes	10
1.7.3	Warnings	10
1.7.4	Safety markings	11
1.8	For your information	11
1.8.1	Language conventions	11
1.8.2	Instructions for actions	12
1.8.3	Information on the type plates	12
1.9	Type plate	14
2	Safety	15
2.1	Requirements for the rider	15
2.2	Personal protective equipment	15
2.3	Proper use	15
2.4	Improper use	16
2.5	Duty of care	16
2.5.1	Rider	16
2.5.2	User	17
3	Description	18
3.1	Overview	18
3.2	Handlebars	19
3.3	Wheel and fork	20
3.3.1	Valve	20
3.4	Brake system	21
3.5	Drive system	22
3.5.1	Battery	23
3.5.1.1	Operating and charge status indicator	24
3.5.2	Driving light	24
3.5.3	Control panel with display	25
3.5.3.1	USB port	26
3.5.3.2	Display	27
3.5.4	Pedal	30

4	Technical data	31
4.1	E-Scooter	31
4.2	USB port	31
4.3	Battery	32
4.4	Control panel with display	32
4.5	Tightening torque	33
5	Transportation, storage and assembly	37
5.1	Transportation	37
5.2	Storing	38
5.2.1	Break in operation	38
5.2.1.1	Preparing a break in operation	39
5.2.1.2	Carrying out break in operation	39
5.3	Assembly	40
5.3.1	Unpacking	40
5.3.2	Scope of delivery	40
5.4	Commissioning	40
5.4.1	Checking the battery	42
5.5	Selling the e-scooter	42
6	Adjusting e-scooter to rider	43
6.1	Setting the handlebars	43
6.1.1	Checking the clamping force of the quick release	44
6.1.1.1	Setting the clamping force	44
6.2	Setting the grip distance of the brake lever	45
7	Operation	46
7.1	Before each ride	48
7.2	Using the kickstand	50
7.2.1	Raising the kickstand	50
7.2.2	Lowering the kickstand	50
7.3	Folding	51
7.3.1	Folding the e-scooter	51
7.3.1.1	Inserting the handlebars	51
7.3.1.2	Folding the stem	52
7.3.2	Folding out the e-scooter	52
7.3.2.1	Folding out the stem	53
7.4	Battery	54
7.4.1	Removing the battery	56
7.4.2	Inserting the battery	57
7.4.3	Charging the battery	58
7.4.4	Waking the battery	60

7.5	Electrical drive system	61
7.5.1	Switching on the drive system	61
7.5.2	Switching off the drive system	61
7.6	Control panel with display	62
7.6.1	Using the driving light	62
7.6.2	Selecting the maximum speed level	62
7.6.3	Functional displays	62
7.6.3.1	Changing the journey information and system functions	62
7.6.3.2	Resetting all the saved journey information	63
7.6.4	Using the USB port	63
7.6.5	Using Bluetooth connection	63
7.6.5.1	Activating Bluetooth connectivity	64
7.6.5.2	Deactivating Bluetooth connectivity	64
7.6.6	Protecting the drive system	64
7.6.6.1	Activating protection of the drive system	64
7.6.6.2	Deactivating protection of the drive system	64
7.6.6.3	Changing the PIN	64
7.7	Pedal	65
7.7.1	Using the pedal	65
7.8	Brakes	66
7.8.1	Using the brake	67
8	Maintenance	68
8.1	Cleaning and servicing	69
8.1.1	Battery	69
8.1.2	Control panel with display	69
8.1.3	Basic cleaning and preservation	70
8.2	Maintaining	71
8.2.1	Wheel	71
8.2.2	Brake system	71
8.2.3	Electrical cables and brake cables	72
8.2.4	USB port	72
8.3	Service	73
8.4	Adjusting and repairing	74
8.4.1	Using original parts only	74
8.4.2	Adjusting the tyre pressure	75
8.4.3	Replacing the lighting	76
8.4.4	Setting the headlight	76
8.4.5	Repair by the specialist dealer	76
8.5	First aid	77
8.5.1	First aid for system messages	78
8.5.1.1	Specific error eradication	79

Table of contents

9	Recycling and disposal	80
10	Appendix	82
10.1	EC declaration of conformity	82
10.2	Spare parts	83
10.3	List of tables	86
10.4	Table of figures	87
10.5	Index	88

1

About these instructions

Read these operating instructions before commissioning the e-scooter, so that you can use all the functions correctly and safely. They are not a substitute for personal training by the supplying specialist dealer. The operating instructions are an integral part of the e-scooter. Therefore, if it is re-sold at a later time, they must be handed over to the subsequent owner.

These operating instructions are mainly intended for the rider and user of the e-scooter, who tend to be technical laypersons.



Text passages which are directed expressly at specialist staff (e.g. bicycle mechanics), are clearly marked with a grey tool symbol.

Staff at all specialist dealers have specialist training and qualifications. They are thus capable of identifying risks and preventing hazards which may arise during maintenance, servicing and repairs on the e-scooter. Information for specialist staff does not require non-professionals to take any action.

1.1

Manufacturer

The e-scooter manufacturer is:

KETTLER Alu-Rad GmbH
Longericher Straße 2
50739 Köln, Germany

Tel.: +49 6805 6008 0
Fax: +49 6805 6008 3098
E-mail: info@KETTLER.de
Internet: www.kettler-alu-rad.de

1.2 **Laws, standards and directives**

These operating instructions comply with the essential requirements from:

- the Machinery Directive 2006/42/EC,
- the Radio Equipment Directive 2014/53/EC,
- EN ISO 12100:2010 Safety of machinery – General principles of design – Risk assessment and reduction,
- EN 15194:2017, Cycles – Electrically power assisted cycles – EPAC bicycles,
- EN 82079-1:2012, Preparation of instructions for use – Structuring, content and presentation – Part 1: General principles and detailed requirements,
- EN ISO 17100:2016-05, Translation Services – Requirements for translation service.

1.3 **Other valid documents**

These operating instructions are only complete in conjunction with the other valid documents.

The following document applies for this product:

- Charger operating instructions,
- Marquardt EC declaration of conformity.

No other information is also applicable.

The constantly updated lists of approved accessories and parts are available to specialist dealers.

1.4 Subject to change

The information contained in these operating instructions are the approved technical specifications at the time of printing. Any significant changes are included in a new issue of the operating instructions. Any changes which are not relevant to safety are published on the following website:

<http://www.kettler-alu-rad.de>

1.5 Language

The original operating instructions are written in German. A translation is not valid without the original operating instructions.

1.6 Identifying

1.6.1 Operating instructions

These operating instructions are printed in colour and glued (PUR glue) in an outer cover made of thin paper. KETTLER Alu-Rad GmbH assumes no liability for copies of any kind, such as black and white copies, loose pages or electronic copies.

The identification number of these operating instructions is made up of the document number, the version number and the release date. It can be found on the cover page and in the footer.

Identification number	877-00113_1.2_06.08.2018
-----------------------	--------------------------

Table 1: Identification number of the operating instructions

1.6.2 E-Scooter

These BMW Motorrad brand operating instructions refer to the *model year* 2018. The production period is from January 2018 to December 2018. They are issued in January 2018.

The operating instructions are an integral part of the following e-scooter:

Type number	Model
KW074-DAMS99	X2City
KW074-DBMS99	X2City
KW074-DCMS99	X2City
KW074-DDMS99	X2City

Table 2: Type number and model categorisation

1.7

For your safety

The e-scooter's safety concept comprises four elements:

- rider and/or user instruction, and e-scooter maintenance and repair by the specialist dealer,
- the chapter on general safety,
- the warnings in these instructions and
- the safety marking on the type plates.

1.7.1

Instruction, training and customer service

The supplying specialist dealer will provide customer service. Contact details can be found on the back page of these operating instructions and in the data sheet. If you are unable to contact your specialist dealer, you will find other specialist dealers to attend to your customer service needs on the website www.kettler-alu-rad.de.



The specialist dealer authorised to perform repairs and maintenance work receives regular training.

The e-scooter rider or user will be instructed on the vehicle functions in person when the supplying specialist dealer hands over the e-scooter, if not before. Instruction particularly focuses on the vehicle's electrical functions and correct use of the charger.

Each rider to whom this e-scooter is provided must receive instruction on its functions. The operating instructions must be submitted to each rider in printed form and must be acknowledged and adhered to.

1.7.2 Basic safety notes

These operating instructions have a chapter with general safety notes [▷ *Chapter 2, page 15*. The chapter stands out because of its grey background.

1.7.3 Warnings

Hazardous situations and actions are marked with warnings. The warnings in these operating instructions are shown as follows:





SIGNAL WORD	Type and source of the danger
	Description of the danger and the consequences.
	▶ Measures
	The following pictograms and signal words are used in the operating instructions for warnings and information notices:
	Will lead to serious or even fatal injuries if ignored. High-risk hazard.
	May lead to serious or even fatal injuries if ignored. Medium-risk hazard.
	May lead to minor or moderate injuries. Low-risk hazard.
	May lead to material damage if ignored.

Table 3: Meanings of the signal words

1.7.4**Safety markings**

The following safety markings are used on the e-scooter's type plates:



General warning



Adhere to the instructions for use

Table 4:

Safety markings on the product**1.8****For your information****1.8.1****Language conventions**

The following terms are used for better legibility:

Term	Meaning
Operating instructions	Original operating instructions or translation of the original operating instructions
E-Scooter	E-Scooter
Motor	Drive motor

Table 5:

Simplified terms

The following conventions are used in these operating instructions:

Convention	Use
<i>Italics</i>	Entry in the index
SPACED	Displays on the <i>control panel with display</i>
[▷ <i>Example, page numbering</i>]	Cross references
•	Bulleted lists

Table 6:

Conventions

1.8.2

Instructions for actions

Instructions for actions are structured in accordance with the following pattern:

- ✓ Requirements (optional)
- ▶ Instruction for action
- ⇒ Result of the action (optional)

1.8.3

Information on the type plates

Alongside warnings, the products' type plates also contain other important information relating to the e-scooter and the charger.



- 1 only suitable for the road, no off-road riding or jumps
 - 2 suitable for roads, off-road riding and jumps of up to 15 cm
 - 3 suitable for rough off-road riding and jumps of up to 61 cm
 - 4 suitable for rough off-road riding and jumps of up to 122 cm
 - 5 suitable for the most difficult terrain
-

Table 7:

Area of use



Read the instructions



Separate collection of electrical and electronic devices



Separate collection of batteries



Must not be thrown into fire (burning prohibited)



Must not be thrown into water (immersed)



Device of protection class II



Only suitable for use indoors



Fuse (device fuse)



EU conformity



Recyclable material

Table 8:

Information on the type plate

1.9

Type plate

The type plate is situated on the *frame*. The type plate features the following information:

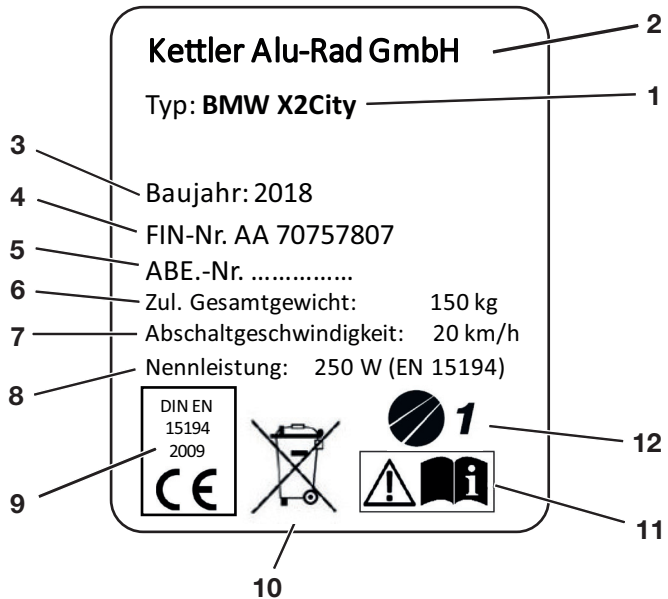

Figure 1:

Type plate, example

- 1 Vehicle name
- 2 Manufacturer
- 3 Year of manufacture
- 4 Vehicle identification no.
- 5 Vehicle Type Approval no.
- 6 Permitted total weight
- 7 Shut-off speed
- 8 Power rating
- 9 CE marking
- 10 Disposal
- 11 Safety notes
- 12 Area of use

2

Safety

2.1

Requirements for the rider

The physical, the mental and motor abilities of the rider must be sufficient for riding on public roads. Legal guardians hold sole responsibility for determining whether minors are capable of using the e-scooter.

2.2

Personal protective equipment

It is recommendable to wear a suitable safety helmet, gloves and knee and elbow guards. We also recommend that you wear close-fitting sports clothing and sturdy footwear.

2.3

Proper use

The e-scooter may only be used in a perfect, fully functional condition. National requirements may apply to the e-scooter which differ from the standard equipment. For riding on public roads, some special regulations apply in relation to *driving light*, *reflectors* and other components. The e-scooter is engineered for short daily journeys on asphalted roads and paths. It is suitable for riding on public roads. The e-scooter is not suitable for off-road riding and jumps. The general laws and the regulations for the prevention of accidents and environmental protection in the respective country of use must be adhered to. Proper use also includes all instructions for actions and check lists in these operating instructions. Approved accessories can be installed by specialist staff.

2.4

Improper use

Failure to adhere to the proper use poses a risk of personal injury and material damage. The e-scooter is not suitable for use under the following circumstances:

- after manipulation to the electrical drive system
- riding with a damaged or incomplete e-scooter
- riding over steps
- riding through deep water
- lending the e-scooter to untrained riders
- carrying further children, people or animals as passengers
- riding with luggage on the handlebars
- riding with no hands
- riding on ice and snow
- improper servicing
- improper repair
- tough areas of use, such as professional competitions
- stunt riding or acrobatics.

2.5

Duty of care

E-scooter safety can only be assured if all necessary measures are taken.

2.5.1

Rider

The rider:

- receives instruction before the first ride. They can clarify any questions relating to the operating instructions with the user or the specialist dealer,
- wears personal protective equipment and
- assumes all the user's obligations if the e-scooter is passed on to someone else.

2.5.2

User

The user has the duty of care and responsibility for scheduling these measures and checking that they are implemented.

The user:

- makes these operating instructions available to the rider for the duration of use of the e-scooter. If necessary, they can translate the operating instructions into a language which the rider understands.
- familiarises the rider with the e-scooter's functions before the first ride. Only riders who have received instruction may be allowed to ride.
- instructs the rider on proper use and the wearing of personal protective equipment.
- only employs specialist staff for e-scooter maintenance and repair.

The printed EC declaration of conformity in the appendix is valid providing that the e-scooter remains unchanged from its original condition. As soon as the user makes any relevant modifications or additions, they legally become the manufacturer. He must independently guarantee compliance with the EC directives again in order to:

- bring the e-scooter into circulation again,
- apply the CE marking and
- avoid compromising occupational safety.

3 Description

3.1 Overview

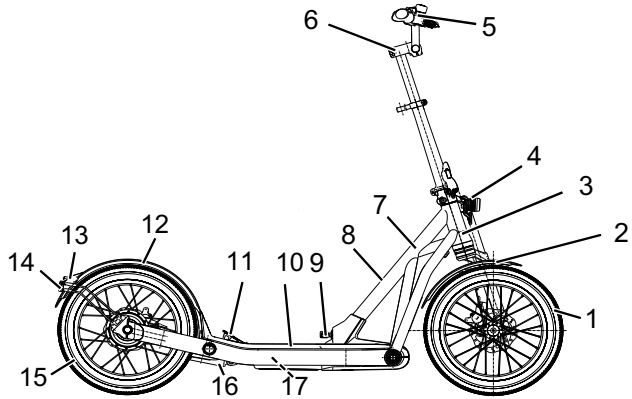
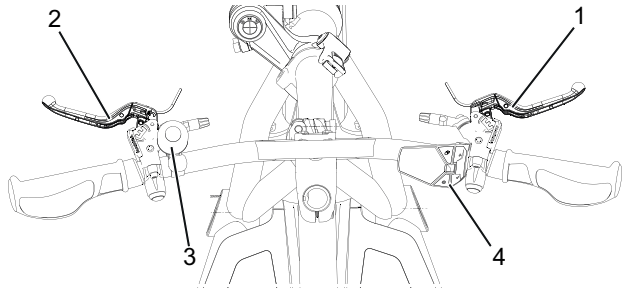

Figure 2: E-scooter, from right

- 1 *Front wheel*
- 2 *Front mudguard*
- 3 *Fork*
- 4 *Headlight*
- 5 *Handlebars*
- 6 *Stem*
- 7 *Frame*
- 8 *Vehicle ID no.*
- 9 *Battery compartment lock*
- 10 *Footboard*
- 11 *Pedal*
- 12 *Rear mudguard*
- 13 *Reflector, front and rear*
- 14 *Rear light*
- 15 *Rear wheel*
- 16 *Kickstand*
- 17 *Battery compartment*

3.2**Handlebars****Figure 3:****Detailed view of e-scooter from rider position**

- 1 Rear brake lever
- 2 Front brake lever
- 3 Bell
- 4 *Control panel with display*

3.3 Wheel and fork

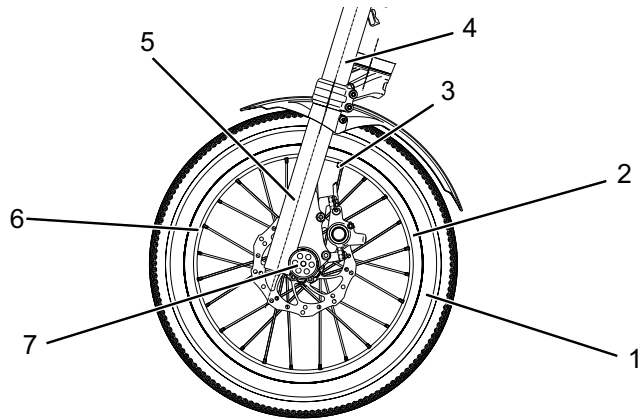

Figure 4: Components of the wheel, example of front wheel

- 1 Tyre
- 2 Rim
- 3 Valve
- 4 Fork
- 5 Spoke
- 6 Hub

3.3.1 Valve

Each wheel has a Schrader valve. It is used to fill the tyre with air. There is a valve cap on each valve. The screw-on valve cap keeps out dust and dirt.

3.4

Brake system

The e-scooter's brake system comprises a hydraulic disc brake on both the front and rear wheel.

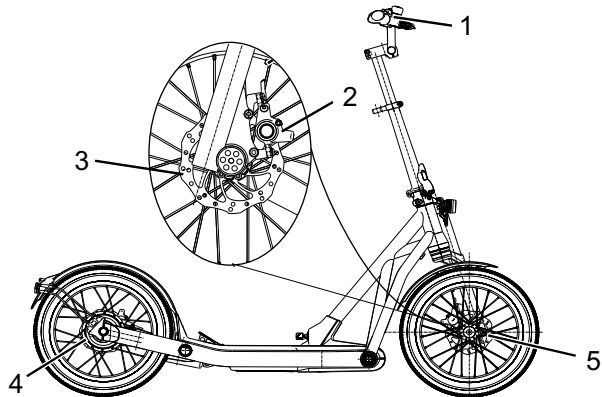

Figure 5:

E-scooter brake system with disc brake

- 1 *Handlebars with brake levers*
- 2 Brake caliper with brake linings
- 3 Brake disc
- 4 Rear wheel brake disc
- 5 Front wheel brake disc

The brake disc is permanently connected to the wheel *hub* on e-scooters with a disc brake. If the brake lever is pulled, the brake linings are pressed against the brake disc, and the movement of the wheel is stopped.

3.5

Drive system

The e-scooter is propelled by leg muscle power pushing on the ground and can be ridden in the same way as a conventional kick scooter.

The e-scooter also has an integrated electric drive system. The electric drive system is made up of seven components:

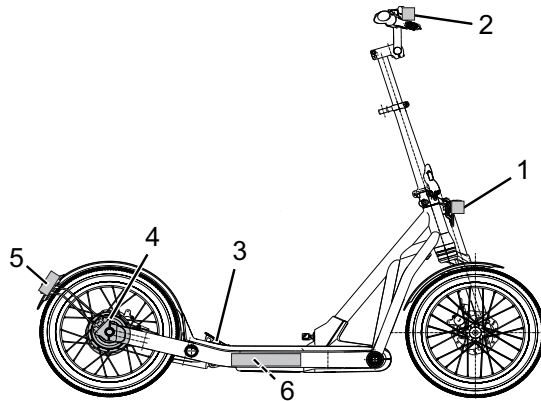

Figure 6:

Diagram of electric drive system

- 1 *Headlight*
- 2 *Control panel with display*
- 3 *Pedal*
- 4 *Motor*
- 5 *Rear light*
- 6 *Battery*
- a charger which is designed for this battery.

As soon as the rider steps on the pedal when travelling at more than 6 km/h, the motor switches on for 5 m and provides the rider's pushing movement with assistance. The motor force is determined by the set speed.

The motor switches off automatically after 5 m if the rider no longer stands on the pedal, a brake is applied, the temperature is outside the permitted range, there is an overload, or the shut-off speed of 20 km/h has been reached.

3.5.1

Battery

The lithium ion battery has an internal electronic protection circuit. It is matched to the charger and the e-scooter. The battery temperature is monitored at all times. The battery is safeguarded against deep discharge, overcharging, overheating and short circuit. In case of a risk the battery is switched off automatically by a protective circuit. The battery also switches to sleep mode for self-protection when not used for a longer period.

The service life of the battery can be extended if it is well cared for and, above all, stored at the correct temperatures. Even if the battery is cared for properly, the charge status of the battery reduces as it ages. If the operating time is severely shortened after charging, this is a sign that the battery is spent.

Transportation temperature	5 °C–25 °C
Storage temperature	5 °C–25 °C
Ideal storage temperature	10 °C–15 °C
Charging ambient temperature	10 °C–30 °C

Table 9:

Battery technical data

The e-scooter has a battery compartment underneath the footboard, which contains the battery.

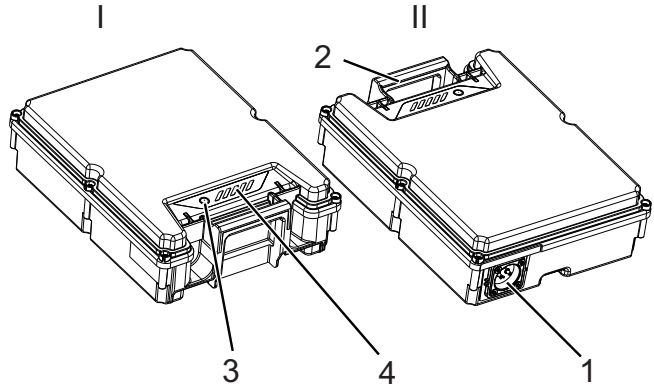

Figure 7: Integrated battery details

- 1 Charging port
- 2 Handle
- 3 On-Off button (battery)
- 4 Operating and charge status indicator

3.5.1.1 Operating and charge status indicator

The five blue LEDs in the operating and charge status indicator signal the battery charge status when the battery is switched on. Each LED represents 20% of the charge status. The charge status of the activated battery is also shown on the *control panel with display*.

3.5.2 Driving light

When the driving light is activated, the *headlight* and the rear light are switched on.

3.5.3

Control panel with display

The control panel with display controls the drive system with five operating elements, and displays the journey data.

Operating temperature -10 °C–65 °C

Storage temperature -20 °C–85 °C

Protection class IP 65

Table 10:

Technical data for the control panel with display

The *control panel with display* has four buttons, a joystick and a USB port.

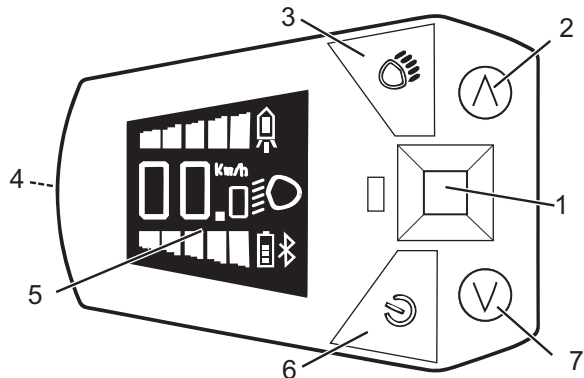

Figure 8:

Details of the control panel with display





Symbol	Use
1	Joystick with menu navigation
2	 Speed level up button
3	 Headlight button
4	USB port
5	Screen
6	 On-Off button (control panel)
7	 Speed level down button

Table 11:

Overview of the control panel with display

3.5.3.1**USB port**

There is a USB port underneath the rubber cover at the bottom edge of the *control panel with display*. The USB port is used as an interface for connecting a fault diagnostics device and for the use of compatible USB devices

Interface	Micro USB standard 2.0 Full Speed
Charge voltage	5 V
Charging current	max. 1 A

Table 12:

USB port technical data

3.5.3.2

Display

The *control panel with display* has five screen displays:

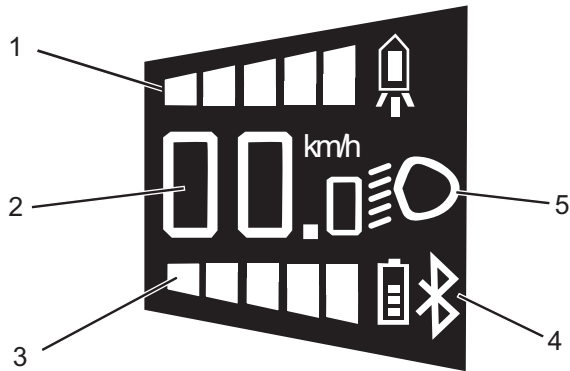

Figure 9:

Overview of the control panel with display

Use	
1	Display of maximum speed levels
2	<i>Function display</i>
3	Battery charge status indicator
4	Bluetooth symbol
5	Driving light symbol

Table 13:

Overview of the control panel with display

Maximum speed levels

When the rider steps on the pedal, the motor is activated until the speed set by the rider has been reached. Six speed levels are available.

Function display

The function display shows different information and functions:

- *Journey information,*
- *System messages and*
- *System functions.*

System functions

The journey information, the Bluetooth connection and the PIN input are changed on the display control panel. The desired functions are called up using the joystick.



Screen	Function
RESET	 Resets the TOUR data to zero
AUS SMARTPHONE	 Sets the Bluetooth connection
AUS PIN AKTIV	Manages the PIN to prevent unauthorised use of the e-scooter

Table 14:

System functions

Journey information

The main screen of the control panel with display shows the current speed in km/h. The displayed screen can be changed using the joystick.

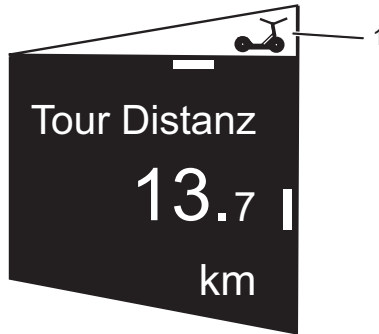

Figure 10:

Example of the tour distance page with e-scooter symbol (1)







Screen	Symbol	Function
RESTREICHWEITE		Anticipated range of the available battery charge, calculated based on the most recent manner of riding
TOUR DISTANZ		Distance in km travelled since the last reset
Ø GESCHW.		Average speed in km/h since the last reset
MAX. GESCHW.		Maximum speed in km/h since the last reset
TOTAL DISTANZ		Total distance travelled
MAX. GESCHW.		Highest speed achieved

Table 15:

Journey information

System message

The drive system monitors itself continuously and if an error is detected, it is indicated by a system message. The system may switch off automatically depending on the type of error. There is a table of system messages in the appendix.

3.5.4

Pedal

The pedal is situated at the rear end of the footboard.

As soon as the rider steps on the pedal with the left or right heel when travelling at more than 6 km/h, the motor switches on briefly and provides the rider's pushing movement with assistance for 5 m. If the rider steps on the pedal regularly, the motor is activated until a maximum speed of 20km/h for Germany and Switzerland has been reached.

4 Technical data

4.1 E-Scooter

Transportation temperature	5 °C–25 °C
Storage temperature	5 °C–25 °C
Ideal storage temperature	10 °C–15 °C
Operation temperature	5 °C–35 °C
Working environment temperature	15 °C–25 °C
Charging temperature	10 °C–30 °C
Power output/system	250 W (0.25 kW)
Shut-off speed	20 km/h for Germany/ Switzerland
Unladen weight	21 kg
Tyre size	16" x 2.6"
Recommended tyre pressure*:	2 - 4 bar

Table 16:

E-scooter technical data

After a tyre change, refer to the tyre marking for the permitted tyre pressure and make sure that it are observed. The pressure must not exceed or drop below this recommended tyre pressure.

4.2 USB port

Interface	Micro USB standard 2.0 Full Speed
Charge voltage	5 V
Charging current	max. 1 A

Table 17:

USB port technical data

4.3

Battery

Transportation temperature	5 °C–25 °C
Storage temperature	5 °C–25 °C
Ideal storage temperature	10 °C–15 °C
Charging ambient temperature	10 °C–30 °C

Table 18:

Battery technical data

4.4

Control panel with display

Operating temperature	-10 °C–65 °C
Storage temperature	-20 °C–85 °C
Protection class	IP 65

Table 19:

Technical data for the control panel with display
Emissions

A-weighted emission sound pressure level < 70 dB(A) by the ear of the rider	
Operating frequency	2402-2480 MHz
max. transmit power (EIRP)	0.43 mW (-3.7 dBm)

Table 20:

Emissions from the e-scooter*

***The safety requirements as per Radio Equipment Directive 2014/53/EU have been met. The e-scooter and charger can be used in residential areas without restriction.**

4.5 Tightening torque

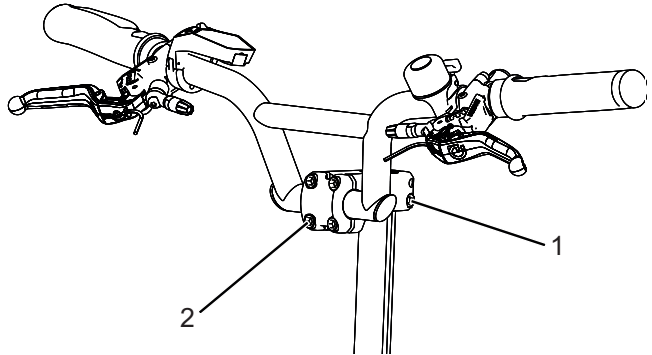

Figure 11: Screw connections on the handlebars

Quantity and screws	maximum tightening torque
1 2 x M7	10.0 Nm
2 4 x M7	10.0 Nm

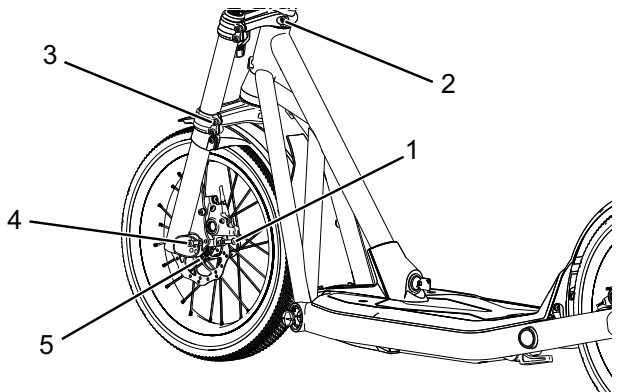

Figure 12: Screw connections on the front wheel and the lower fork, from the left

Quantity and screws	maximum tightening torque
1 2 x M6 x 20	10.0 Nm
2 1 x M6 x 25	6.0 Nm
3 4 x M6 x 25	10.0 Nm
4 1 x M5 x 30	1.0 Nm
5 2 x M6 x 16	10.0 Nm
6 6 x M5 x 10	4.0 Nm

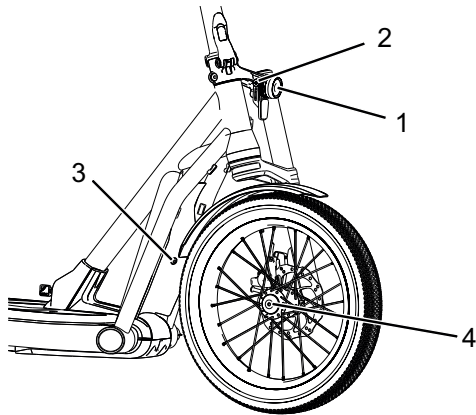

Figure 13: Screw connections on the front wheel and the lower fork, from the right

Quantity and screws		maximum tightening torque
1	1 x M6 x 30	as far as it will go
2	1 x M6	2.0 Nm
3	2 x M5 x 16	2.6 Nm
4	1 x M8	15.0 Nm

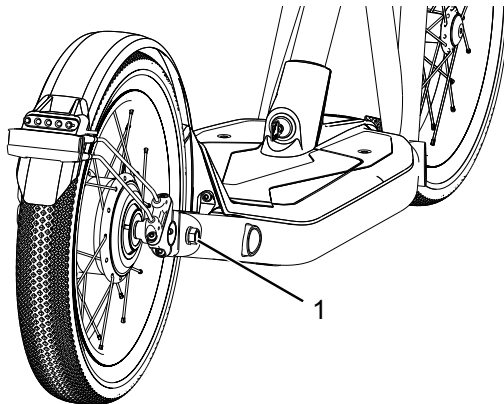

Figure 14: Screw connections on the rear wheel, from the right

Quantity and screws		maximum tightening torque
1	2 x M12 x 1.25	18.0 Nm

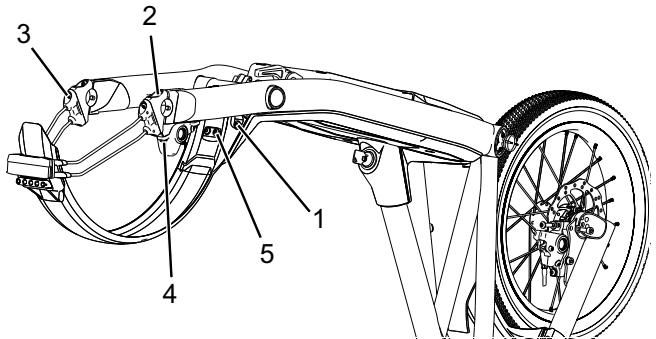

Figure 15: Screw connections on the rear wheel, from below

Quantity and screws		maximum tightening torque
1	2 x M5 x 12	0.8 Nm
2	4 x M6 x 25	10.0 Nm
3	4 x M5 x 12	4.0 Nm
4	2 x M6 x 20	10.0 Nm
5	2 x M5 x 12	0.8 Nm

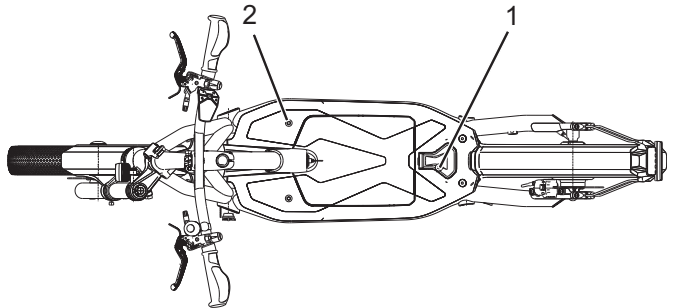

Figure 16: Footboard screw connections, from above

Quantity and screws		maximum tightening torque
1	1 x M8 x 20	10.0 Nm
2	4 x M8 x 30	8.0 Nm

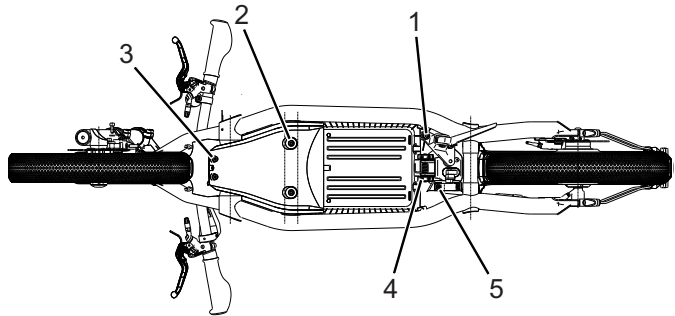

Figure 17:

Footboard screw connections, from below

	Quantity and screws	maximum tightening torque
1	2 x M8 x 20	6.0 Nm
2	2 x M5 x 16	2.6 Nm
3	2 x STS KN1038 5 x 20	0.2 Nm
4	4 x STS Kn1038 4 x 20	2.0 - 2.1 Nm
5	2 x M5 x 12	0.8 Nm

5 Transportation, storage and assembly

5.1 Transportation



Unintentional activation

The rear wheel hub motor can be activated by operating the pedal while the rear wheel is turning. There is a risk of injury.

- ▶ Remove the battery before the e-scooter is transported.



Risk of fire and explosion due to high temperatures

Excessively high temperatures damage the batteries. The batteries may self-ignite and explode.

- ▶ Never expose the battery to sustained direct sunlight.



NOTICE

If the shipping box containing an e-scooter is placed flat or on one end, it does not provide adequate protection from damage to the *frame* and the wheels.

- ▶ Transport the e-scooter in an upright position only.
- ▶ Take into account the weight of the ready-to-use e-scooter when transporting it.
- ▶ Protect the electrical components and connections on the e-scooter from the elements with suitable protective covers.
- ▶ Transport the e-scooter in a dry, clean position which is protected from direct sunlight.

5.2

Storing



Risk of fire and explosion due to high temperatures

Excessively high temperatures damage the battery. The battery may self-ignite and explode.

- ▶ Never expose the battery to sustained direct sunlight.

NOTICE

If the shipping box containing an e-scooter is placed flat or on one end, it does not provide adequate protection from damage to the *frame* and the wheels.

- ▶ Store the e-scooter in an upright position only.
- ✓ Store the scooter, battery and charger in a dry, clean place.

Storage temperature	5 °C–25 °C
Ideal storage temperature	10 °C–15 °C

Table 21:

Storage temperature for the battery, e-scooter and charger

5.2.1

Break in operation

NOTICE

The battery discharges when it is not used. This can cause damage to the battery.

- ▶ The battery has to be recharged every 8 weeks.

NOTICE

The battery may become damaged if it is connected permanently to the charger.

- ▶ Do not connect the battery to the charger permanently.

If the e-scooter is to be removed from service for longer than four weeks, e.g. in winter, you need to prepare it for a break in operation.

5.2.1.1

Preparing a break in operation

- ✓ Remove the battery from the e-scooter.
- ✓ Charge the battery to around 60% (three to four LEDs of the charge status indicator light up).
- ✓ The e-scooter needs to be cleaned with a damp cloth and preserved with wax spray. Never wax the friction surfaces of the brake or the brake disc.
- ✓ Before longer periods without use, it is recommendable to have your specialist dealer carry out servicing and basic cleaning and apply preservative agent.
- ✓ Reduce the tyre pressure to 1.5 to 2 bar.

5.2.1.2

Carrying out break in operation

- ▶ Store the e-scooter, battery and charger in a dry and clean environment.
- ▶ Check the charge status of the battery after 8 weeks. If only one LED of the charge status indicator lights up, recharge the battery to around 60%.

5.3



Assembly

- ✓ Assemble the e-scooter in a clean and dry environment.
- ✓ The working environment temperature should be between 15 °C and 25 °C.

Working environment temperature

15 °C–25 °C

Table 22:

Working environment temperature

- ✓ Universal tools, a torque spanner with an operating range of 0.2 Nm to 18 Nm and the special tools, as recommended by KETTLER Alu-Rad GmbH, must be available.

5.3.1

Unpacking

The packaging material consists mainly of cardboard and plastic film.

- ▶ The packaging has to be disposed of in accordance with the regulations of the authorities.

5.3.2

Scope of delivery

The scope of delivery includes:

- the e-scooter
- the battery
- the charger
- the operating instructions.

5.4

Commissioning

Initial commissioning includes the following work:

- ▶ *Check the battery.*
- ▶ The battery is supplied partially charged. In order to guarantee full power, *charge the battery* fully.
- ▶ *Open up the e-scooter.*

- ▶ Move the handlebars and stem into the functional position.
- ▶ Move the brake handles, control panel with display and the bell into position. Screw all the components in place.
- ▶ Check the entire cable harness to make sure that it is routed properly:
 - You must prevent the cable harness from coming into contact with moving parts.
 - The cable routes must be smooth and free from sharp edges.
 - Moving parts must not apply any pressure or tension to the cable harness.
- ▶ Check the plug connections on the motor, control device, control panel with display and light sensor.
- ▶ Check the torque on all screw connections with a torque spanner.
- ▶ Check all the components to make sure that they are firmly in place.
- ▶ Set the *headlight*.
- ▶ Carry out a test ride to check the drive system, the light equipment and the brakes to make sure that they are fully functional and effective.
- ▶ Set the drive system has to the national language and the appropriate system of measurement.
- ▶ Check the drive system's software version for country-specific variants.

5.4.1

Checking the battery



Fire and explosion caused by incorrect charger

Batteries which are charged with an unsuitable charger, may become internally damaged. This may result in fire or an explosion.

- ▶ Only ever use the battery with the supplied charger.
- ▶ Label the supplied charger and these operating instructions clearly to prevent any mix-ups. You can use the e-scooter's *frame number* or *type number*, for example.

The battery has to be checked before it is charged for the first time.

- ▶ Press the *On-Off button (battery)*.
- ⇒ If none of the LEDs on the operating and charge status indicator light up, the battery may be damaged.
- ▶ If at least one of the LEDs of the operating and charge status indicator lights up, but not all of them, the battery can be charged.
- ▶ Once the battery has been charged, insert it into the e-scooter.

5.5

Selling the e-scooter

- ▶ Adjust the e-scooter to the rider.
- ▶ Show the purchaser how the *e-scooter is opened up*.
- ▶ Instruct the purchaser how to use all the e-scooter's functions.

6 Adjusting e-scooter to rider

6.1 Setting the handlebars



Crash caused by incorrectly set clamping force

Excessively high clamping force will damage the quick release and cause it to lose its function.

Insufficient clamping force will cause a detrimental transmission of force. This can cause components to break. This will result in a crash and injuries.

- ▶ Never fasten a quick release using a tool (e.g. hammer or pliers).
- ▶ Only use the clamping lever with the specified set clamping force.

Maximum tightening torque for the clamping screws of the handlebars*

10 Nm

Table 23:

Handlebars clamping screw maximum tightening torque

- ▶ Open the clamping lever for the quick release on the stem.
- ▶ Pull out the handlebars to the required height.
- ▶ Lock the quick release.
- ▶ Check the clamping force of the quick releases.

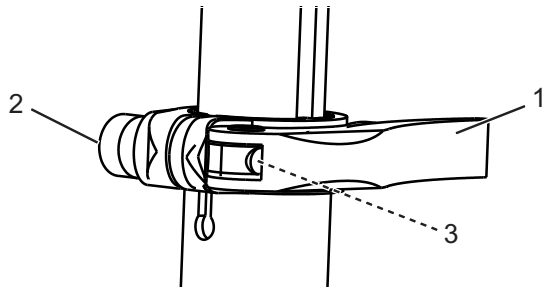

Figure 18: Closed clamping lever (1) with knurled nut (2) and locking screw (3) on the stem

6.1.1 Checking the clamping force of the quick release

- ▶ Open and close the stem quick release.
- ⇒ The clamping force is sufficient if the clamping lever can be moved easily from the open final position into the middle and has to be pressed with the fingers or base of the thumb from the middle point onwards.

6.1.1.1 Setting the clamping force

- ▶ If the *clamping lever on the handlebars* cannot be moved into its final position, screw out the *knurled nut*.
- ▶ Tighten the *knurled nut* on the handlebars if the *clamping lever's* clamping force is not sufficient.



If you are unable to set the clamping force, the specialist dealer will need to check the quick release.

6.2

Setting the grip distance of the brake lever



The specialist dealer can adjust the brake lever to the rider's grip distance.

- ▶ Set the grip distance by turning the setting screw (2) on the brake lever with a Torx T25.
- ⇒ The rider can use the brake lever comfortably.

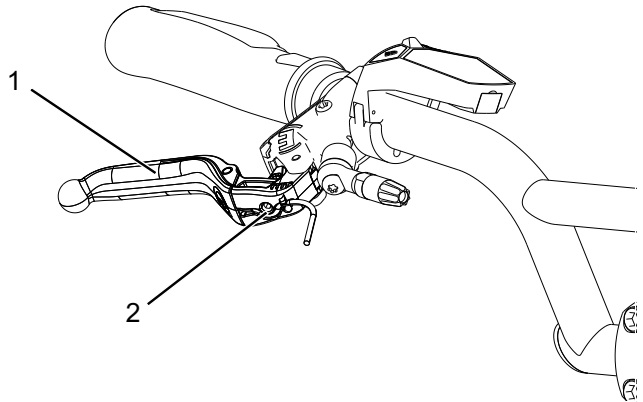

Figure 19:

Brake lever (1) with setting screw (2)

7

Operation



Crash caused by loose clothing

Laces, scarves and other loose items may become entangled in the spokes on the *wheels* and the brake discs. Such damage may cause you to fall from the vehicle and injure yourself.

- ▶ Wear sturdy footwear and close-fitting clothing.
-



Crash caused by soiling

Heavy soiling can impair the e-scooter's functions, for example, such as correct functioning of the brakes. Such damage may cause you to fall from the vehicle and injure yourself.

- ▶ Remove coarse soiling before riding.
-



Crash caused by poor road conditions

Loose objects, for example, branches and twigs, may become caught in the wheels. The braking distance is longer in the wet. Such damage may cause you to fall from the vehicle and injure yourself.

- ▶ Be aware of the road conditions.
 - ▶ Ride slowly and brake in good time.
-



When riding downhill, high speeds may be reached. The e-scooter is only designed to exceed a speed of 20 km/h briefly. In particular the *tyres* can fail if exposed to a continuous load.

- ▶ Decelerate the e-scooter if you reach speeds greater than 20 km/h.
 - ▶ Braking intermittently prevents the brake discs or brake linings from overheating.
-

NOTICE

Heat or direct sunlight can cause the *tyre pressure* to increase above the permitted maximum pressure. This can destroy the *tyres*.

- ▶ Never park the e-scooter in the sun.
- ▶ On hot days, regularly check the *tyre pressure* and adjust it as necessary.

You can ride the e-scooter within a temperature range of 5 °C–35 °C. The effectiveness of the drive system is restricted outside of this temperature range.

Operation temperature

5 °C–35 °C

Moisture penetrating at low temperatures may impair individual vehicle functions due to the open structural design.

7.1

Before each ride



Crash caused by difficult-to-spot damage

After a crash, accident or if the e-scooter falls over, there may be damage which is hard to detect, e.g. to the brake system or the *frame*. Such damage may cause you to fall from the vehicle and injure yourself.

- ▶ Take the e-scooter out of service and have a specialist dealer carry out an inspection.
-



Crash caused by material fatigue

A component may suddenly fail in case of material fatigue. Such damage may cause you to fall from the vehicle and injure yourself.

- ▶ Remove the e-scooter from service immediately in case of any signs of material fatigue. Have the specialist dealer check the state.
 - ▶ Have the specialist dealer carry out basic cleaning regularly. During basic cleaning, the specialist dealer will inspect the e-scooter for any signs of material fatigue.
-
- ▶ Check the e-scooter before each ride.
- ⇒ If there are any discrepancies from the *Check list before each ride* or any anomalies of any kind, the e-scooter must not be used until the cause has been clarified.

Check list before each ride

<input type="checkbox"/>	Check that the e-scooter is complete.
<input type="checkbox"/>	Check that the lighting, reflector and brake, for instance, are sufficiently clean.
<input type="checkbox"/>	Check that the mudguards are securely installed.
<input type="checkbox"/>	Check that the front and rear wheels run true. This is particularly important if the e-scooter has been transported or secured with a lock.
<input type="checkbox"/>	Check the valves and the tyre pressure. Adjust the tyre pressure as necessary before each ride.
<input type="checkbox"/>	Check the front and rear wheel brakes to make sure that they are working properly. To do so, operate the brake levers while stationary in order to check whether resistance is generated in the usual brake lever position.
<input type="checkbox"/>	Check that the driving light is working.
<input type="checkbox"/>	Check for unusual noises, vibrations, smells, discolouration, deformation, abrasion and wear. This indicates material fatigue.
<input type="checkbox"/>	Be alert to any unusual operating sensations when braking, pedalling or steering.
<input type="checkbox"/>	Check the spokes.
<input type="checkbox"/>	Check the tyres for wear.

7.2

Using the kickstand



Crash caused by a lowered kickstand

The kickstand does not fold up automatically. There is a risk of crashing if riding with the kickstand lowered.

- ▶ Raise the kickstand completely before the ride.
-

NOTICE

The heavy weight of the e-scooter may cause the kickstand to sink into soft ground and the e-scooter may topple and fall over.

- ▶ The e-scooter must be parked on level, firm ground only.
-

7.2.1

Raising the kickstand

- ▶ Before the ride, raise the kickstand completely with your foot.

7.2.2

Lowering the kickstand

- ▶ Before parking, lower the kickstand completely with your foot.
- ▶ Park the e-scooter carefully and check that it is stable.

7.3

Folding

NOTICE

- ▶ Never crush or bend electric cables or brake cables when folding the e-scooter.

7.3.1

Folding the e-scooter

The e-scooter is folded in four steps.

- ▶ Switch off the *electric drive system*.
- ▶ Remove the *battery* if necessary
- ▶ Use the *kickstand*.
- ▶ Fold the *stem*.

7.3.1.1

Inserting the handlebars

- ▶ Open the *clamping lever on the stem quick release*.
- ▶ Push in the *handlebars*.
- ▶ Close the *clamping lever on the stem quick release*.

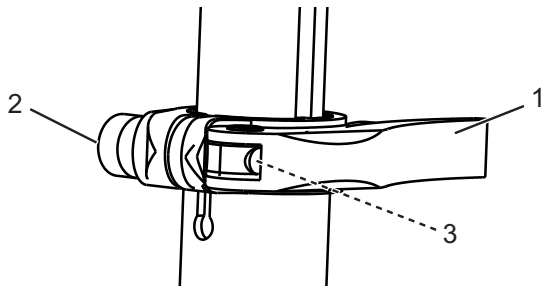

Figure 20:

Closed clamping lever (1) with knurled nut (2) and locking screw (3) on the stem

7.3.1.2

Folding the stem

- ▶ Press the *frame locking lever* downwards (1) while pushing the integrated locking lever upwards at the same time.
- ▶ Pull the locking bolt forward (2).
- ▶ Pivot in the frame as far as it will go (3).

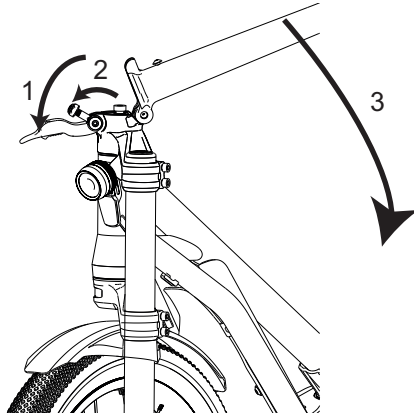

Figure 21:

Frame, with the frame clamping lever open (1), locking bolt pushed forward (2) and stem half open (3)

7.3.2

Folding out the e-scooter

The e-scooter is folded out in four steps.

- ▶ Use the *kickstand*.
- ▶ *Fold out the stem*.
- ▶ *Set the handlebars*.
- ▶ If necessary, *insert the battery*.

7.3.2.1**Folding out the stem**

- ▶ Completely fold out the frame.
 - ▶ Push the securing pin into the frame (1).
 - ▶ Close the *frame clamping lever*.
- ⇒ The *frame clamping lever* rests on the limit stop. The *frame locking lever* holds the *frame clamping lever*. The *frame clamping lever* is closed.

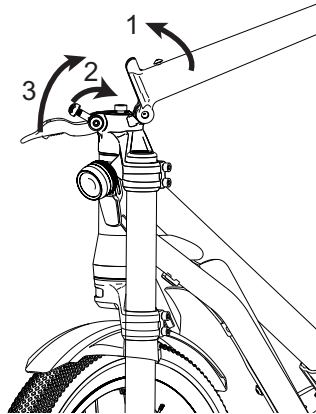
**Figure 22:**

Frame, with the stem half open (1), locking bolt pushed forward (2) and the frame clamping lever open (3)

7.4

Battery



Risk of fire and explosion due to faulty battery

The safety electronics on damaged or faulty batteries may fail. The residual voltage can cause a short circuit. The batteries may self-ignite and explode.

- ▶ Remove batteries with external damage from service immediately and never charge them.
- ▶ If the battery becomes deformed or begins to smoke, keep at a safe distance, disconnect the power supply at the socket, and notify the fire service immediately.
- ▶ Never extinguish damaged batteries with water or allow them to come into contact with water.
- ▶ If a battery is dropped or struck but shows no signs of external damage, remove the battery from service and observe it for at least 24 hours.
- ▶ Faulty batteries are hazardous goods. Dispose of faulty batteries properly and as quickly as possible.
- ▶ Store in a dry place until disposal. Never store in the vicinity of flammable substances.
- ▶ Never open or repair the battery.



Risk of fire and explosion due to high temperatures

Excessively high temperatures damage the battery. The battery may self-ignite and explode.

- ▶ Never expose the battery to sustained direct sunlight.
-



Fire and explosion caused by short circuit

Small metal objects may jumper the electrical connections of the battery. The batteries may self-ignite and explode.

- ▶ Keep paper clips, screws, coins, keys and other small parts away from the battery and do not insert them into the battery.



Chemical burns to the skin and eyes caused by faulty battery

Liquids and vapours may leak from damaged or faulty batteries. They can irritate the airways and cause burns.

- ▶ Avoid contact with leaked liquids.
- ▶ Immediately consult a doctor in case of contact with the eyes or any discomfort.
- ▶ In case of contact with the skin, rinse off immediately with water.
- ▶ Ventilate the room well.



Fire and explosion caused by penetration by water

The battery is only protected from simple spray water. Penetration by water can cause a short circuit. The battery may self-ignite and explode.

- ▶ Never immerse the battery in water.
 - ▶ If there is reason to believe that water may enter into the battery, the battery must be removed from service.
-

NOTICE

If a key is left inserted when riding or transporting the e-scooter, it may break off or the lock may open accidentally.

- ▶ Remove the key from the battery lock immediately after use.
 - ▶ We recommend that you attach the key to a key ring.
-
- ✓ Before the battery is to be removed or inserted, switch off the battery and the drive system.

7.4.1

Removing the battery

- ▶ Open the battery lock with the key.
- ▶ Open the battery compartment cover.

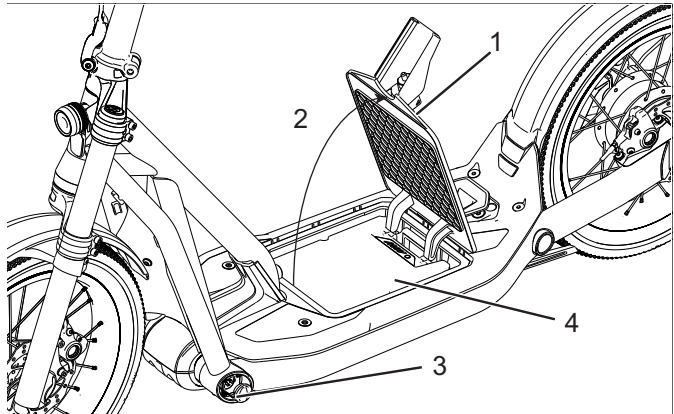

Figure 23:

Open (2) the battery compartment cover (1) and the external charging port (3) and remove the battery (4)

- ▶ Lift the battery out of the battery compartment by the handle.
- ▶ Close the battery compartment cover.
- ▶ Remove the key from the battery lock.

7.4.2**Inserting the battery**

- ▶ Open the battery lock with the key.
- ▶ Open the battery compartment cover.
- ▶ Place the battery in the frame with the contacts facing in the direction of travel, taking hold of the battery by the handle.
- ▶ Close the battery compartment cover.
- ▶ Close the battery lock with the key.
- ▶ Remove the key from the battery lock.

7.4.3

Charging the battery



Fire caused by overheated charger

The charger heats up when charging the battery. In case of insufficient cooling, this can result in fire or burns to the hands.

- ▶ Never use the charger on a highly flammable surface (e.g. paper, carpet etc.).
 - ▶ Never cover the charger during the charging process.
-



Electric shock caused by penetration by water

If water penetrates into the charger, there is a risk of electric shock.

- ▶ Never charge the battery outdoors.
-



Electric shock in case of damage

Damaged chargers, cables and plug connectors increase the risk of electric shock.

- ▶ Check the charger, cable and plug connector before each use. Never use a damaged charger.
 - ▶ The ambient temperature during the charging process must be within the range from 10 °C to 30 °C.
-

Charging temperature	10 °C - 30 °C
-----------------------------	---------------

- ✓ The battery can remain on the e-scooter or be removed for charging.
- ✓ Interrupting the charging process does not damage the battery.
- ▶ Remove the rubber cover from the external battery port.

-
- ▶ Connect the mains plug of the charger to a normal domestic, grounded socket.

Connection data230 V, 50 Hz

- ▶ Connect the charging cable to the battery's charging port.
- ⇒ The charging process starts automatically.
- ⇒ During the charging process the operating and charge status indicator indicates the charge status. When the drive system is switched on, the *control panel with display* shows the charging process.
- ⇒ The charging process is complete when the LEDs of the operating and charge status indicator go out.

 **Risk of fire and explosion caused by damaged batteries.** The safety electronics on damaged or faulty batteries may fail. The residual voltage can cause a short circuit. The batteries may self-ignite and explode. If the battery becomes deformed or begins to smoke, keep at a safe distance, disconnect the power supply at the socket, and notify the fire service immediately. Never extinguish damaged batteries with water or allow them to come into contact with water.

 If an error occurs during the charging process, a system message is displayed. Remove the charger and the battery from operation immediately and follow the instructions.

7.4.4

Waking the battery

- ✓ When not used for a longer period, the battery switches to sleep mode for self-protection. The LEDs of the operating and charge status indicator do not light up.
- ▶ Press the **On-Off button (battery)**.
- ▶ The battery's operating and charge status indicator indicates the charge status.

7.5 Electrical drive system

7.5.1 Switching on the drive system

- ✓ A sufficiently charged battery has been inserted into the e-scooter.
- ✓ The battery is firmly in place. The key has been removed.
- ✓ After switching off, the drive system shuts down. It is possible to switch back on immediately. Wait a moment as necessary.

There are two options for switching on the drive system.

1 Battery On-Off button

- ▶ Press the **On-Off button (battery)** once.

2 On-Off button, control panel with display

- ▶ Press the **On-Off button (control panel with display)** for longer than 0.5 seconds and max. 2 seconds.

⇒ If the drive system is switched on, the drive is activated as soon as the pedals are moved with sufficient force.

7.5.2 Switching off the drive system

The system switches off automatically ten minutes after the last command. There are two options for switching off the drive system manually.

1 On-Off key, control panel with display

- ▶ Press the **On-Off button (control panel with display)** for longer than 2 seconds.

2 Battery On-Off key

- ▶ Press the **On-Off button (battery)** for longer than 2 seconds.

7.6 Control panel with display

7.6.1 Using the driving light

- ✓ To switch on the *driving light*, the drive system has to be switched on already.
- ▶ Press the **headlight button** briefly.
- ⇒ The *driving light* is switched on, and the *driving light symbol* is displayed.
- ▶ Press and hold the **headlight button** for longer than two seconds.
- ⇒ The *running light* is switched off, and the *driving light symbol* is not displayed.

7.6.2 Selecting the maximum speed level

- ▶ Press the **speed level up button**.
- ⇒ The speed is increased.
- ▶ Press the **speed level down button**.
- ⇒ The speed is reduced.

7.6.3 Functional displays

The displayed *functional displays* can be changed and partially reset.

7.6.3.1 Changing the journey information and system functions

- ▶ Move the joystick to the left or right until the required *journey information* or *system function* is displayed.
- ⇒ The selected item of *journey information* or *system function* is activated and is shown on the display.

7.6.3.2

Resetting all the saved journey information

- ▶ Move the **joystick** to the right again until the required *journey information* TOUR DISTANZ is displayed.
 - ▶ Move the **joystick** downwards until the desired *journey information* RESET is displayed. Press the joystick down again and RESET will be highlighted in grey.
 - ▶ Press the **joystick** in its centre position.
- ⇒ All the values in the TOUR DISTANZ have been reset.

7.6.4

Using the USB port

The USB port can be used to operate external devices which can be connected using a standard micro A/micro B USB 2.0 cable.

- ▶ Open the protective flap on the USB port.
- ▶ Replace the protective flap after using the USB port.

NOTICE

Any moisture which enters through the USB port may cause corrosion damage on the *control panel with display*. Regularly check the position of the rubber cover on the USB port and adjust it as necessary.

7.6.5

Using Bluetooth connection

An active Bluetooth connection can establish a connection to external devices. This enables data exchange.

7.6.5.1

Activating Bluetooth connectivity

- ▶ Select the item of journey information BLUETOOTH.
- ▶ Select the device type to be used for data exchange.
- ▶ Go to the main screen.
- ⇒ Connect the Bluetooth device to the control panel. For this, follow the instructions on the Bluetooth device.
- ⇒ The control panel exchanges data with the Bluetooth device. It may take a while to establish the connection.

7.6.5.2

Deactivating Bluetooth connectivity

- ▶ Select the item of journey information BLUETOOTH.
- ▶ Activate AUS option (off).
- ⇒ The control panel no longer transmits signals. Bluetooth connectivity is cancelled.

7.6.6

Protecting the drive system

In order to prevent unauthorised use of the drive system, a PIN can be activated to protect the system.

- ✓ The PIN is set to 0000 on delivery.

7.6.6.1

Activating protection of the drive system

- ✓ The drive system is not protected by the PIN.
- ✓ Enter the PIN.

7.6.6.2

Deactivating protection of the drive system

- ✓ The drive system is protected by the PIN.
- ▶ Enter the PIN.

7.6.6.3

Changing the PIN

- ▶ Confirm the change with the old PIN.
- ▶ Enter the new PIN twice.

7.7

Pedal

7.7.1

Using the pedal

- ▶ Use your foot to accelerate the e-scooter to at least 6 km/h.
- ▶ Use your left or right heel to step on the pedal.
- ⇒ The motor is activated briefly and provides assistance to the pedalling movement for 5 m.
- ▶ If the rider steps on the pedal regularly, the motor is activated until the set maximum speed has been reached.

7.8

Brakes



Crash caused by incorrect use

Handling the brake improperly can lead to loss of control or crashes, which may result in injuries.

- ▶ Practice braking and emergency braking before using the e-scooter in public spaces.
- ▶ Shift your weight back and down as far as possible.



Crash caused by wet conditions

The tyres may slip on wet roads. In wet conditions you must also expect a longer braking distance. The braking sensation differs from the usual sensation. This can cause loss of control or a crash, which may result in injuries.

- ▶ Ride slowly and brake in good time.



Crash after cleaning, servicing or repair

The braking effect may be unusually weak temporarily after cleaning, servicing or repairing the e-scooter. Such damage may cause you to fall from the vehicle and injure yourself.

- ▶ After cleaning, servicing or repair, carry out a few test brake applications.



Burns caused by heated brake

The brakes may become very hot during operation. There is a risk of burns in case of contact.

- ▶ Never touch the components of the brake directly after the ride.
-

If the rider steps on the pedal with his/her heel, the drive force of the motor is switched off for 5 m. The drive system switches off immediately when braking.

7.8.1

Using the brake

- ▶ Pull the *brake levers* until the desired speed has been reached.

8 Maintenance

Cleaning check list

<input type="checkbox"/>	Cleaning the plug contacts	before each charging process
<input type="checkbox"/>	Cleaning the battery	once a month
<input type="checkbox"/>	Basic cleaning and preservation of all components	at least every six months
<input type="checkbox"/>	Clean the charger	at least every six months

Maintenance check list

<input type="checkbox"/>	Check USB rubber cover position	before each ride
<input type="checkbox"/>	Checking the spring-loaded plug contacts	before each charging process
<input type="checkbox"/>	Check for tyre wear	once a week
<input type="checkbox"/>	Check for rim wear	once a week
<input type="checkbox"/>	Check the tyre pressure	once a week
<input type="checkbox"/>	Check brakes for wear	once a month
<input type="checkbox"/>	Checking the electrical cables and hydraulic lines for damage and to make sure they are fully functional	once a month
<input type="checkbox"/>	Check the tension of the spokes	every three months

Service check list

<input type="checkbox"/>	Inspection by the specialist dealer	every six months
--------------------------	-------------------------------------	------------------

8.1

Cleaning and servicing



Unintentional activation

The rear wheel hub motor can be activated by operating the pedal while the rear wheel is turning. There is a risk of injury.

- ▶ Remove the battery before cleaning.

The following servicing measures must be carried out regularly [[▶ Check list, page 68](#)]. Servicing can be performed by the user and rider. In case of any doubt, consult the specialist dealer.

8.1.1

Battery



Fire and explosion caused by penetration by water

The battery is only protected from simple spray water. Penetration by water can cause a short circuit. The battery may self-ignite and explode.

- ▶ Never clean the battery with a high-pressure water device, water jet or compressed air.
 - ▶ Never immerse the battery in water.
 - ▶ Remove the battery from the e-scooter before cleaning.
-
- ▶ Only clean the electrical connections of the battery with a dry cloth or brush.
 - ▶ Wipe off the decorative sides with a damp cloth.

8.1.2

Control panel with display

- ▶ Carefully clean the *control panel with display* with a damp, soft cloth.

8.1.3

Basic cleaning and preservation



Crash caused by brake failure

The braking effect may be unusually weak temporarily after cleaning, servicing or repairing the e-scooter. Such damage may cause you to fall from the vehicle and injure yourself.

- ▶ Never apply care products or oil to the brake discs or brake linings.
 - ▶ After cleaning, servicing or repair, carry out a few test brake applications.
-

NOTICE

Water may enter into the inside of the bearings if you use a steam jet. Lubrication is no longer ensured. There is a risk of corrosion which can lead to bearing damage

- ▶ Never clean the e-scooter with a steam jet.
 - ▶ Clean the e-scooter with a damp cloth. Mix a little neutral soap with the cleaning water.
 - ▶ Then use wax or oil on the e-scooter as a preservative agent.
-

8.2

Maintaining



Unintentional activation

The rear wheel hub motor can be activated by operating the pedal while the rear wheel is turning. There is a risk of injury.

- ▶ Remove the battery before maintenance.

The following maintenance measures must be carried out regularly [*> Check list, page 68*]. They can be carried out by the user and rider. In case of any doubt, consult the specialist dealer.

8.2.1

Wheel

NOTICE

If the pressure is too low in the tyre, the tyre does not achieve its load bearing capacity. The tyre is not stable and may come off the rim.

If the pressure in the tyre is too high, the tyre may burst.

- ▶ Check the tyre pressure against the specifications
- ▶ *Adjust the tyre pressure as necessary.*

-
- ▶ Check the *tyre wear*.
 - ▶ *Check the rims for damage.*
 - ▶ Check the tension of the spokes.

8.2.2

Brake system

- ▶ Replace the brake linings on the disc brake when the pad thickness has reached 0.5 mm.

8.2.3

Electrical cables and brake cables

- ▶ Check all visible electrical cables and hydraulic lines for damage. If, for example, hydraulic lines are cracked or buckled, the e-scooter will need to be removed from service until the cables have been replaced.
- ▶ Check all electrical cables and hydraulic lines to make sure they are fully functional.

8.2.4

USB port

NOTICE

Any moisture which enters through the USB port may cause corrosion damage on the *control panel with display*.

- ▶ Regularly check the position of the *cover on the USB port* and adjust it as necessary.
-

8.3

Service**Unintentional activation**

The rear wheel hub motor can be activated by operating the pedal while the rear wheel is turning. There is a risk of injury.

- ▶ Remove the battery before the service.

**Crash caused by material fatigue**

If the service life of a component has expired, the component may suddenly fail. Such damage may cause you to fall from the vehicle and injure yourself.

- ▶ Have the specialist dealer carry out six-monthly basic cleaning of the e-scooter, preferably at the same time as mandatory servicing work.

The specialist dealer must perform an inspection at least every six months. This is the only way to ensure that the e-scooter remains safe and fully functional.



- ▶ During basic cleaning, the specialist dealer will inspect the e-scooter for any signs of material fatigue.
- ▶ The specialist dealer will check the software version of the drive system and update it. The electrical connections are checked, cleaned and preservative agent is applied. The electrical cables are inspected for damage.
- ▶ Particular attention is paid to the rim and brake wear. The spokes are re-tightened in accordance with the findings.

8.4

Adjusting and repairing



Unintentional activation

The rear wheel hub motor can be activated by operating the pedal while the rear wheel is turning. There is a risk of injury.

- ▶ Remove the battery before adjusting and repairing.
-

8.4.1

Using original parts only

The individual e-scooter parts have been carefully selected and matched to one other.

Only original parts must be used for maintenance and repair.

The constantly updated lists of approved accessories and parts are available to specialist dealers.

8.4.2

Adjusting the tyre pressure

- ✓ It is recommendable to use an air pump with a pressure gauge. The operating instructions for the air pump must be adhered to.
- ▶ Unscrew and remove the valve cap.
- ▶ Connect the air pump.
- ▶ Pump up the tyre slowly and pay attention to the tyre pressure in the process.
- ⇒ The tyre pressure has been adjusted as per the specifications.
- ▶ Remove the air pump.
- ▶ Screw the valve cap tight.
- ▶ Screw the rim nut gently against the rim with the tips of your fingers.



Figure 24:

Schrader valve with rim nut (1)

8.4.3

Replacing the lighting

- ▶ Only use components of the respective power class for replacement.

8.4.4

Setting the headlight

- ▶ The *headlight* must be positioned, so that its light beam meets the road 10 m in front of the e-scooter.

8.4.5

Repair by the specialist dealer



Special knowledge and tools are required for many repairs. Only a specialist dealer may carry out the following repairs, for instance:

- Replacing *tyres* and rims,
- Replacing brake linings

8.5

First aid

Proceed as follows if the control panel with display and/or the drive system fail to start up:

- ▶ Check whether the battery is switched on. If not, start the battery.
- ⇒ Contact specialist dealer if the charge status indicator LEDs do not light up.
- ▶ If the LEDs of the charge status indicator light up, but the drive system does not start up, remove the battery.
- ▶ Insert the battery.
- ▶ Start the drive system.
- ▶ If the drive system does not start up, remove the battery.
- ▶ Clean all the contacts with a soft cloth.
- ▶ Insert the battery.
- ▶ Start the drive system.
- ▶ Contact your specialist dealer if the drive system does not start up.

8.5.1

First aid for system messages



Fire and explosion due to faulty batteries

The safety electronics on damaged or faulty batteries may fail. The residual voltage can cause a short circuit. The batteries may self-ignite and explode.

- ▶ Batteries with external damage must be removed from service immediately.
 - ▶ Never allow damaged batteries to come into contact with water.
 - ▶ If a battery is dropped or struck but shows no signs of external damage, remove the battery from service and observe it for at least 24 hours.
 - ▶ Faulty batteries are hazardous goods. Dispose of faulty batteries properly and as quickly as possible.
 - ▶ Store in a dry place until disposal. Never store in the vicinity of flammable substances.
 - ▶ Never open or repair the battery.
-

The components of the drive system are checked constantly and automatically. If an error is detected, the respective error code appears on the *control panel with display*. The drive may be shut off automatically, depending on the type of error.

If a system message is displayed, run through the following actions:

- ▶ Make a note of the system message.
- ▶ Shut off and re-start the drive system.
- ▶ If the system message is still displayed, remove and then re-insert the battery.
- ▶ Re-start the drive system.
- ▶ Contact your specialist dealer if the system message is still displayed.

8.5.1.1

Specific error eradication

If the following system messages appear, the rider must act as follows:

Error	Remedy
10	▶ Charge the battery.
12	▶ Charge the battery.
24	Incorrect charger. ▶ Use the supplied charger for charging.
40, 41, 44	Overcurrent detected and motor overheating ▶ Relieve the motor by using a reduce speed level.

Table 24:

Troubleshooting with the help of the system messages

9

Recycling and disposal



Risk of fire and explosion

The safety electronics on damaged or faulty batteries may fail. The residual voltage can cause a short circuit. The batteries may self-ignite and explode.

- ▶ Remove batteries with external damage from service immediately and never charge them.
- ▶ If the battery becomes deformed or begins to smoke, keep at a safe distance, disconnect the power supply at the socket, and notify the fire service immediately.
- ▶ Never extinguish damaged batteries with water or allow them to come into contact with water.
- ▶ Faulty batteries are hazardous goods. Dispose of faulty batteries properly and as quickly as possible.
- ▶ Store in a dry place until disposal. Never store in the vicinity of flammable substances.
- ▶ Never open or repair the battery.



Chemical burns to the skin and eyes

Liquids and vapours may leak from damaged or faulty batteries. They can irritate the airways and cause burns.

- ▶ Avoid contact with leaked liquids.
 - ▶ Immediately consult a doctor in case of contact with the eyes or any discomfort.
 - ▶ In case of contact with the skin, rinse off immediately with water.
 - ▶ Ventilate the room well.
-

The e-scooter, battery, control panel with display and charger are recyclable. You must dispose of and recycle them separately from the domestic waste in compliance with applicable statutory regulations.



Separate collection and recycling saves reserves of raw materials and ensures that all the regulations for protection of health and the environment are adhered to when recycling the product and/or the battery.

- ▶ Never dismantle the e-scooter, battery or charger for disposal.
- ▶ The e-scooter, control panel with display, unopened and undamaged battery and charger can be returned to any specialist dealer free of charge. Depending on the region, further disposal options may be available.
- ▶ Store the individual parts of the decommissioned e-scooter in a dry place, free from frost, where they are protected from direct sunlight.

10 Appendix

10.1 EC declaration of conformity

Translation of the original EC declaration of conformity

The manufacturer:

KETTLER Alu-Rad GmbH
Abteilung Motorisierung
Longericher Str. 2
50739 Köln Germany



hereby declares that the electrically power assisted cycles of types:

KW074-DAMS99, KW074-DBMS99, KW074-DCMS99 and KW074-DDMS99

year of manufacture 2017 and year of manufacture 2018,

comply with all applicable requirements of **Machinery Directive 2006/42/EC**. Furthermore, the electrically power assisted cycles comply with all applicable basic requirements of **Electromagnetic Compatibility Directive 2014/30/EU** and the **Radio Equipment Directive 2014/53/EU**.

The following standards were applied: **EN ISO 12100:2010** Safety of machinery – General principles of design – Risk assessment and reduction; **EN ISO 4210-2:2015**, Cycles – Safety requirements for bicycles – Part 2: Requirements for city and trekking, young adult, mountain and racing bicycles; **EN 15194:2017**, Cycles – Electrically power assisted cycles – EPAC bicycles.

Mr Robert Bobinger
c/o BMW Group,
Forschung, Neue Technologien, Innovationen
Fahrzeugtechnik und Technologien (LT-22)
Konzepte E-Bikes
Parkring 19-23,
85748 Garching
Germany

is authorised to compile the technical documentation.

Cologne, 06.08.2018
.....

Place, date and signature

Egbert Hageböck

-Chairman-

10.2

Spare parts

Spare parts have to be replaced as necessary as a result of wear. Only the following spare parts must be used:

<i>Description</i>	<i>Article number</i>
16" Vee Rubber tyre	P0NHRT1
Rim 16" x 50 mm	P0G5WZ1 / P062GP2
Spoke	P0G5XA7
Front wheel hub	P0BCMZ7
Deep groove ball bearing 61805-2RSR	P0BBWK7
Deep groove ball bearing 61804-2RSR	P0BBWL9
VA bearing spacer	P0BGXX9
Front wheel spacer sleeve	P0BH4Q1
Front wheel bearing cover plate	P0BH5T8
Brake disc	P0HTPB1
MAGURA adapter QM43 ISV 160	P0HY6F3
MAGURA front wheel brake MT NEXT 2 4 C	P0HTPA9
Brake linings (blue)	P0VGRO4
Fork stanchion X2CITY	P0K8NC7
Fork bridge rubber wedge, bottom	P0HJMO6
Lower fork bridge	P0DW3X1
Headset clamp	P8U7843
Headset bearing, bottom, 1.5" 36 45	P0BC8U5
ACROS headset (bearing seat shell)	PYB5216
ACROS headset (bearing)	PYB5216
ACROS headset (plastic sleeve)	PYB5216
ACROS headset (O-ring)	PYB5216
ACROS headset (rubber ball)	PYB5216
Fork bridge rubber wedge, top	P0HJMO5

Table 25:

Spare parts

<i>Description</i>	<i>Article number</i>
Fork tube cover plate	P0P6FL9
BMW badge D=27	2328447
Headset clamp cover / Top Cap1 1/8	PYB6642
ZB handlebars shaft with fork bridge, top	P0HGDV0
Stem	P0JTSZ1
Handlebar grips	P03K5E7
Bell	P0B1BW3
MARQUARDT JUST DRIVE display screen	P09GZW2
Handlebars	P0JTVR6
MAGURA rear wheel brake MT NEXT 2 4 C	P0HTPA9
Rear wheel spokes	P062GP2
Hub motor	P062GP2
Lft socket, DAPU hub motor	P0B1DN4
Rgt socket, DAPU hub motor	P0B1CY1
Aluminium mount, mudguard struts	P0N0BD3
Mudguard strut, bottom	P0NFHV9
Mudguard strut, top	P0NFHV9
Rear wheel cover	P0NF3U4
Tail lamp holder	P0NF3U0
SUPERNOVA rear light M99	P0DT1O8
Z large reflector	P0HM8A3
Trapezoidal mount, rear mudguard	P0H6NZ7
Frame X2CITY	P09HGA2
Footboard well	P0NF3T0
Footboard cover	P0NF3T7
Battery compartment cover seal EPDM 25SHORE A	P0NKPA3
Battery lock Make M0103 0575 100	P09NPH3
Griptape X2CITY	P0JSSG0

Table 25:

Spare parts

Description	Article number
MARQUARDT pedal sensor	P09XC13
Kickstand X2CITY	P0FCXG5
Rechargeable battery X2CITY	P0DR5Y4
Pedal X2CITY	P0DLSW4
Magnetic pedal holder X2CITY	P0B3QP8
Collar bushing IGUS JVFM-0810-10	P0GXMR8
Collar bushing IGUS WFM-0810-07	P0B1PZ9
Pedal bearing bolt X2CITY	P0B1QE6
Leg spring Pedal X2CITY	P07JGY0
Lft pedal axle shaft fastener	P0KYTH4
Rosenberger charging socket hold-down plate	P0FKNZ0
CCU motor controller	P0HYFX4
Panel section, front top	P0NF3T8
Panel section, front bottom	P0NF3T9
Splash guard	P0NF3U6
Front wheel cover	P0NF3U3
SUPERNOVA MINI 5 - 21 V DC 6 V 4 W	P0JMFD7
SUPERNOVA front spotlight	P0JMFD7

Table 25:

Spare parts

10.3

List of tables

Table 1:	Identification number of the operating instructions, 8
Table 2:	Type number and model categorisation, 8
Table 3:	Meanings of the signal words, 10
Table 4:	Safety markings on the product, 11
Table 5:	Simplified terms, 11
Table 6:	Conventions, 11
Table 7:	Area of use, 12
Table 8:	Information on the type plate, 13
Table 9:	Battery technical data, 23
Table 10:	Technical data for the control panel with display, 25
Table 11:	Overview of the control panel with display, 25
Table 12:	USB port technical data, 26
Table 13:	Overview of the control panel with display, 27
Table 14:	System functions, 28
Table 15:	Journey information, 29
Table 16:	E-scooter technical data, 31
Table 17:	USB port technical data, 31
Table 18:	Battery technical data, 32
Table 19:	Technical data for the control panel with display, 32
Table 20:	Emissions from the e-scooter*, 32
Table 21:	Storage temperature for the battery, e-scooter and charger, 38
Table 22:	Working environment temperature, 40
Table 23:	Handlebars clamping screw maximum tightening torque, 43
Table 24:	Troubleshooting with the help of the system messages, 79
Table 25:	Spare parts, 83

10.4 Table of figures

Figure 1:	Type plate, example, 14
Figure 2:	E-scooter, from right, 18
Figure 3:	Detailed view of e-scooter from rider position, 19
Figure 4:	Components of the wheel, example of front wheel, 20
Figure 5:	E-scooter brake system with disc brake, 21
Figure 6:	Diagram of electric drive system, 22
Figure 7:	Integrated battery details, 24
Figure 8:	Details of the control panel with display, 25
Figure 9:	Overview of the control panel with display, 27
Figure 10:	Example of the tour distance page with e-scooter symbol (1), 29
Figure 11:	Screw connections on the handlebars, 33
Figure 12:	Screw connections on the front wheel and the lower fork, from the left, 33
Figure 13:	Screw connections on the front wheel and the lower fork, from the right, 34
Figure 14:	Screw connections on the rear wheel, from the right, 34
Figure 15:	Screw connections on the rear wheel, from below, 35
Figure 16:	Footboard screw connections, from above, 35
Figure 17:	Footboard screw connections, from below, 36
Figure 18:	Closed clamping lever (1) with knurled nut (2) and locking screw (3) on the stem, 44
Figure 19:	Brake lever (1) with setting screw (2), 45
Figure 20:	Closed clamping lever (1) with knurled nut (2) and locking screw (3) on the stem, 51
Figure 21:	Frame, with the frame clamping lever open (1), locking bolt pushed forward (2) and stem half open (3), 52
Figure 22:	Frame, with the stem half open (1), locking bolt pushed forward (2) and the frame clamping lever open (3), 53
Figure 23:	Open (2) the battery compartment cover (1) and the external charging port (3) and remove the battery (4), 56
Figure 24:	Schrader valve with rim nut (1), 75

10.5

Index

- A**
 Area of use, 12
 Assembly, 40
- B**
 Basic cleaning and preservation,
 cleaning and servicing, 70
 Basic cleaning, 70
 Battery compartment, 18
 Lock, 18
 Battery, 22, 23, 54
 - charging, 58
 - checking, 42
 - cleaning and servicing, 69
 - disposing of, 81
 - eliminating charging errors, 78
 - inserting, 57
 - removing, 56
 - waking, 60
 Handle, 24
 Range, 29
 Bell, 19
 Bluetooth, 28
 - activating, 64
 - deactivating, 64
 Screen display, 27
 Brake caliper, 21
 Brake disc, 21
 Brake lever, 19
 - setting grip distance, 45
 Brake lining, 21
 - maintaining, 71
 Brake,
 - braking, 67
 Brakes, 66
 maintenance, 71
 Break in operation, 38
 - carrying out, 39
 - preparing, 39
- C**
 Chain,
 Tension, 72
 Charge status indicator, 24, 27
- Charger,
 - disposing of, 81
 Charging port, 24
 Checklist,
 before each ride, 49
 Cleaning, 68
 Maintenance, 68
 Commissioning, 40
 Control panel with display, 22, 25, 62
 - cleaning, 69
- D**
 Distance travelled, 29
 Drive system, 22, 61
 - protecting, 64
 - switching off, 61
 - switching on, 61
 Driving light,
 - checking function, 49
- E**
 EC declaration of conformity, 82
 Electrical cables,
 - maintenance, 72
 Error message, see System message,
F
 Folding, 51
 - folding out, 52
 Footboard, 18
 Fork, 20
 Front wheel brake,
 Front wheel brake, see brake
 Front wheel, see Wheel
 Function screen, 27, 28
 - switching, 62
- H**
 Handlebars quick release,
 - checking the clamping force, 44
 Handlebars, 19
 - inserting, 51
 - installing, 40
 - setting, 43
 Headlight button, 25
 Highest speed achieved, 29
- Hub, 20
- J**
 Journey information, 29
 - resetting, 63
 - switching, 62
 Joystick, 25
- K**
 Kickstand,
 - using, 50
- L**
 Level of assistance,
 - selecting, 62
 Light, 24
 - using, 62
 Headlight button, 25
 Headlight, 18, 22
 Rear light, 18, 22
 Screen display, 27
- M**
 Manufacturer, 14
 Motor, 22
 Mudguards, 18
 - checking, 49
- O**
 On-Off button,
 Battery, 24
 Control panel, 25
- P**
 Parts list, 82
 Pedal, 22, 30
 - using, 65
 PIN, 28, 64
 - changing, 64
- R**
 Rear wheel brake, see brake
 Rear wheel, see Wheel
 Reflector, 18
 Rim, 20
 - checking, 71
 - replacing, 76
- S**
 Safety, 15
 Screen display, 27
 Speed level display, 27

- Speed level, 28
 - selecting, 62
- Down button, 25
- Up button, 25
- Speed,
 - Average, 29
 - Shut-off speed 31
- Spoke, 20
- Stand, see kickstand
- Stem, 18
 - folding out, 53
 - folding, 52
- Storing, 38
- System function, 28
- System message, 30
 - First aid, 78
 - Table, 79
- T**
- Technical data 31
- Tightening torque, 33
- Total distance travelled, 29
- Transportation, 37
- Type plate, 14
- Tyre size, 31
- Tyres, 20
 - checking, 71
 - replacing, 76
 - Tyre pressure, 31
- U**
- USB port, 25, 26
 - maintenance, 72
 - using, 63
- V**
- Valve, 20
 - Adjusting the tyre pressure, 75
- Vehicle name, 14
- W**
- Weight,
 - permitted total weight, 14
- Wheel, 20
 - maintenance, 71
- Winter break, see break in operation

Text and images:
KETTLER Alu-Rad GmbH
Longericher Straße 2
50739 Köln, Germany

Translation:
Tanner Translations GmbH+Co
Markenstraße 7
40227 Düsseldorf, Germany

Operating instructions: 877-00113 1.2 06.08.2018

www.kettler-alu-rad.de

KETTLER Alu-Rad GmbH
Longericher Straße 2
50739 Köln, Germany

Tel.: +49 6805 6008 0

Fax: +49 6805 6008 3098

E-mail: info@kettler-alu-rad.de

YOUR SPECIALIST DEALER

